

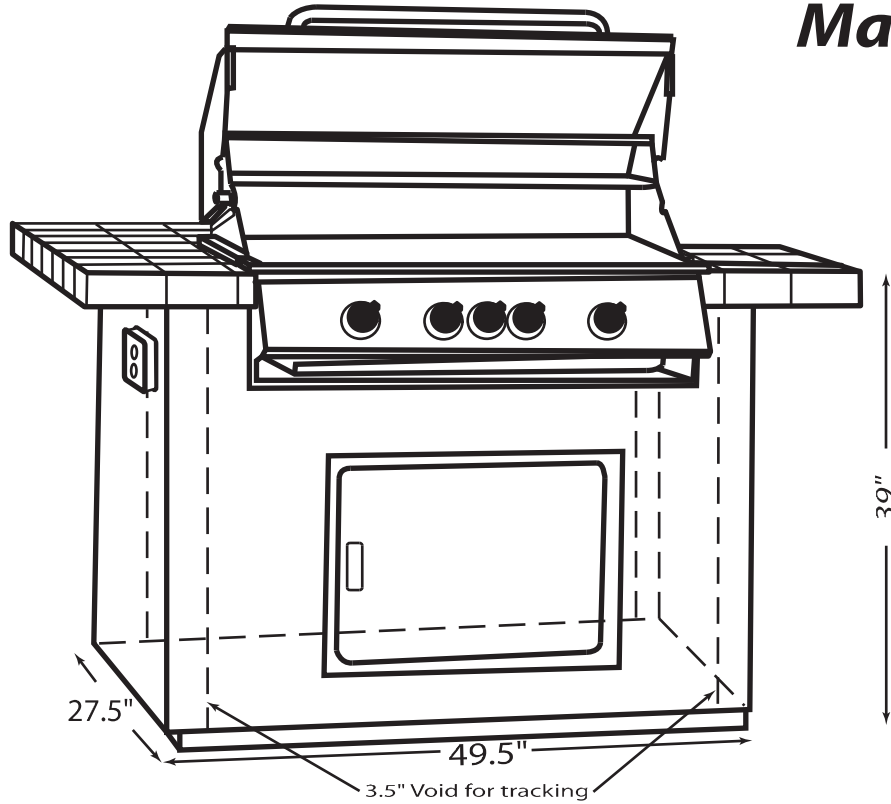

Product Spec Sheet

Drawing not to Scale

Master-Q



For Utility Stub-Up Locations See
Utility Stub-Up Drawing

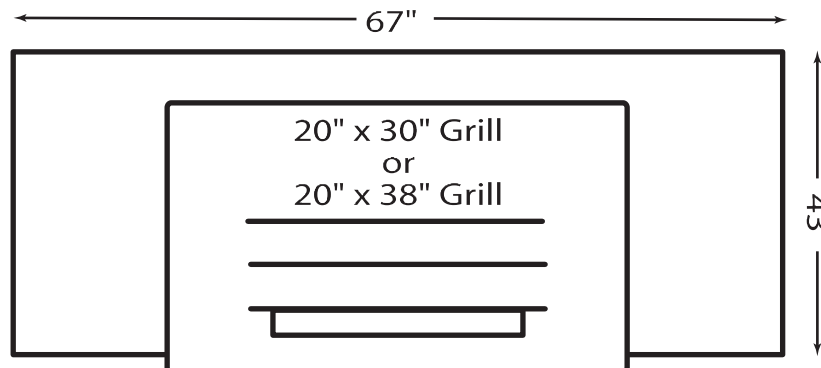

Base Dimension = 27.5" x 49.5"